

INTERNAL SOFT CLOSING DAMPER SIMON

Index	Door weight	Markings	Opening force
A-SOFT-30	max 30kg	25	18 - 25N
A-SOFT-50	max 50kg	40 17N	38 - 45N

Set includes	
Product	Quantity
Internal soft closing damper (25 or 40 17N)	2 pcs.
Roller - 5 x 12 - M3 (Novo S 18/4)	4 pcs.
Lock washer - 4	4 pcs.
Screw - M3 x 12 (frame)	4 pcs.
Activator	2 pcs.

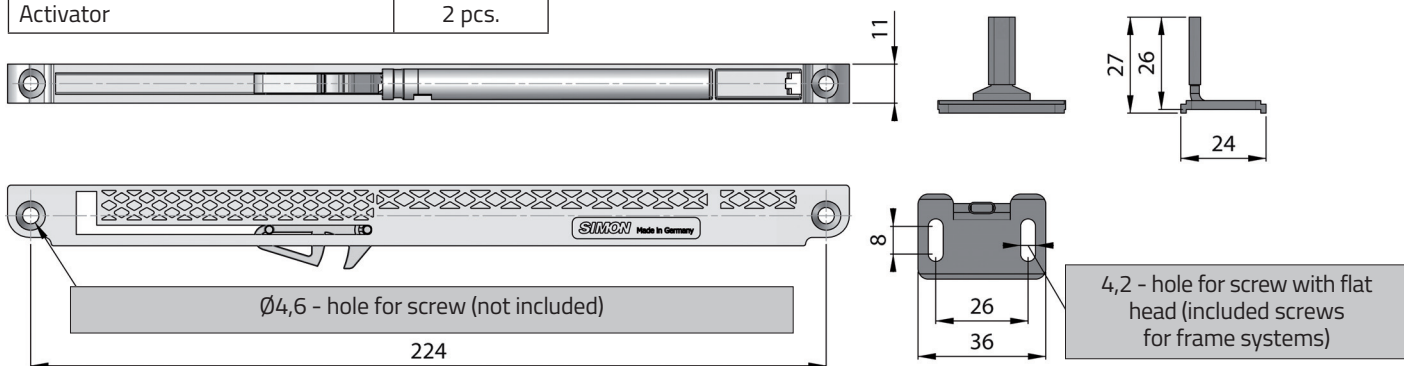
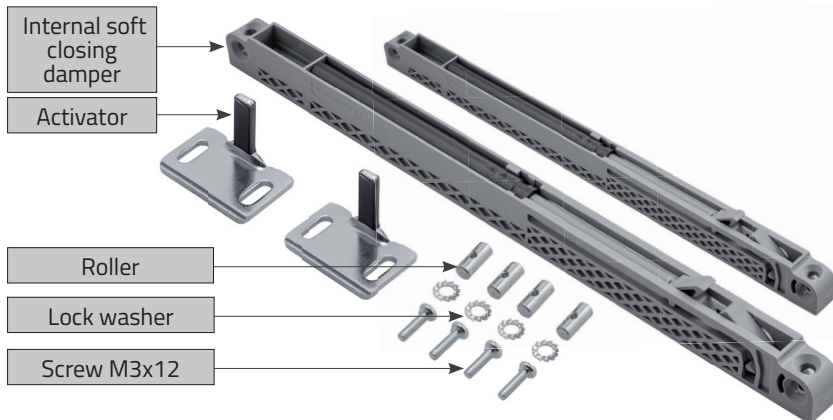

INSTALLATION DIMENSIONS FOR SOFT CLOSING DAMPER: ERGO (18), NOVO S (18), NOVO S (16)

When using the internal soft closing damper and the activator at full length, adjustment of the door height is between 0 and 3mm/

If there is a need for regulation in a wider range - shorten the stem of the activator
Mounting dimensions of the door remain unchanged

Before installation, please activate the damper* - 64 mm for doors with brush strips, 65 mm for doors without brush strips

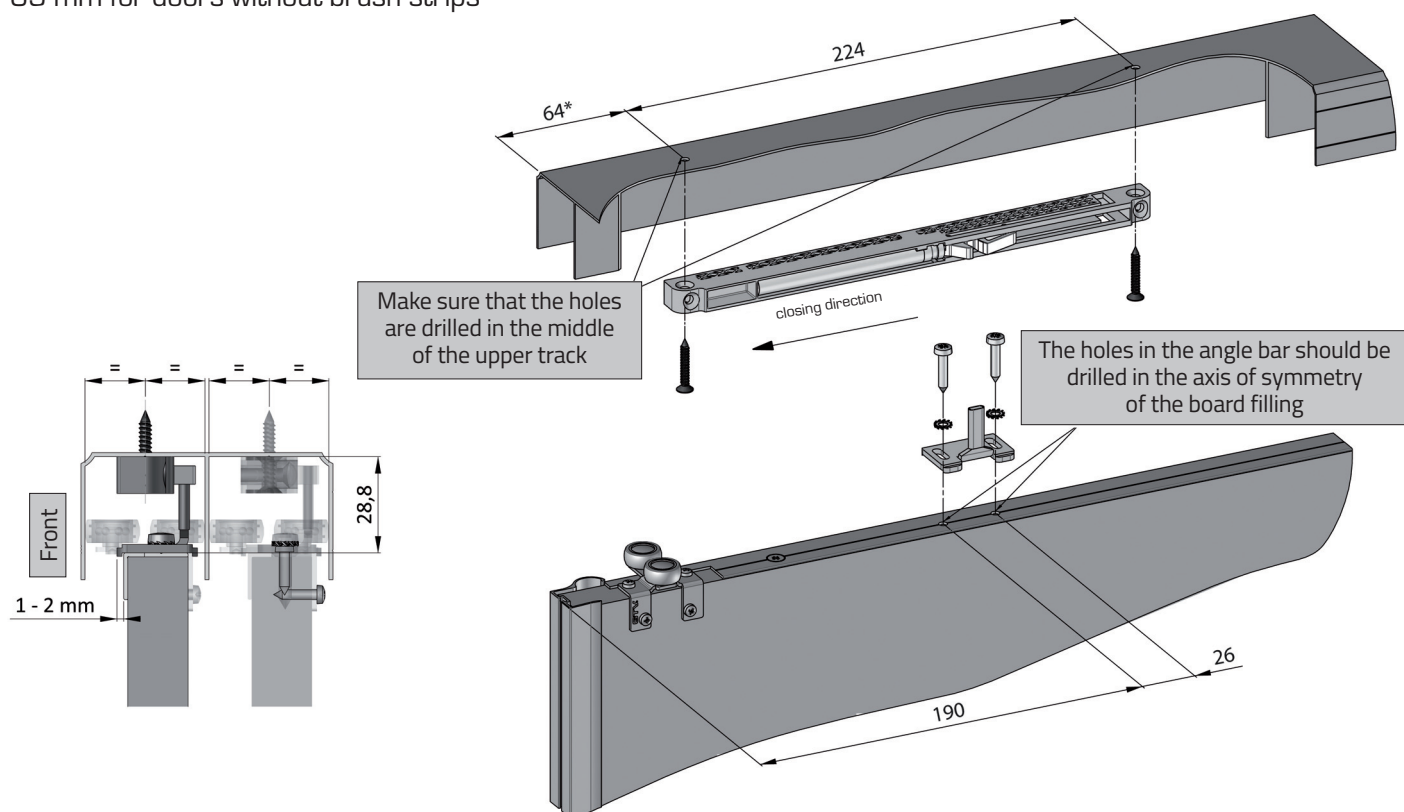

MOUNTING DIMENSIONS OF THE INTERNAL SOFT CLOSING DAMPER IN FRAME SYSTEMS ERGO (18), NOVO (18), NOVO S (16)

When using the internal soft closing damper and the activator at full length, adjustment of the door height is between 0 and 3mm

If there is a need for regulation in a wider range - shorten the stem of the activator

Mounting dimensions remain unchained. Before installing the doors tension the clutch.

*64 mm for doors without buffer strip, 65 mm with buffer strip.

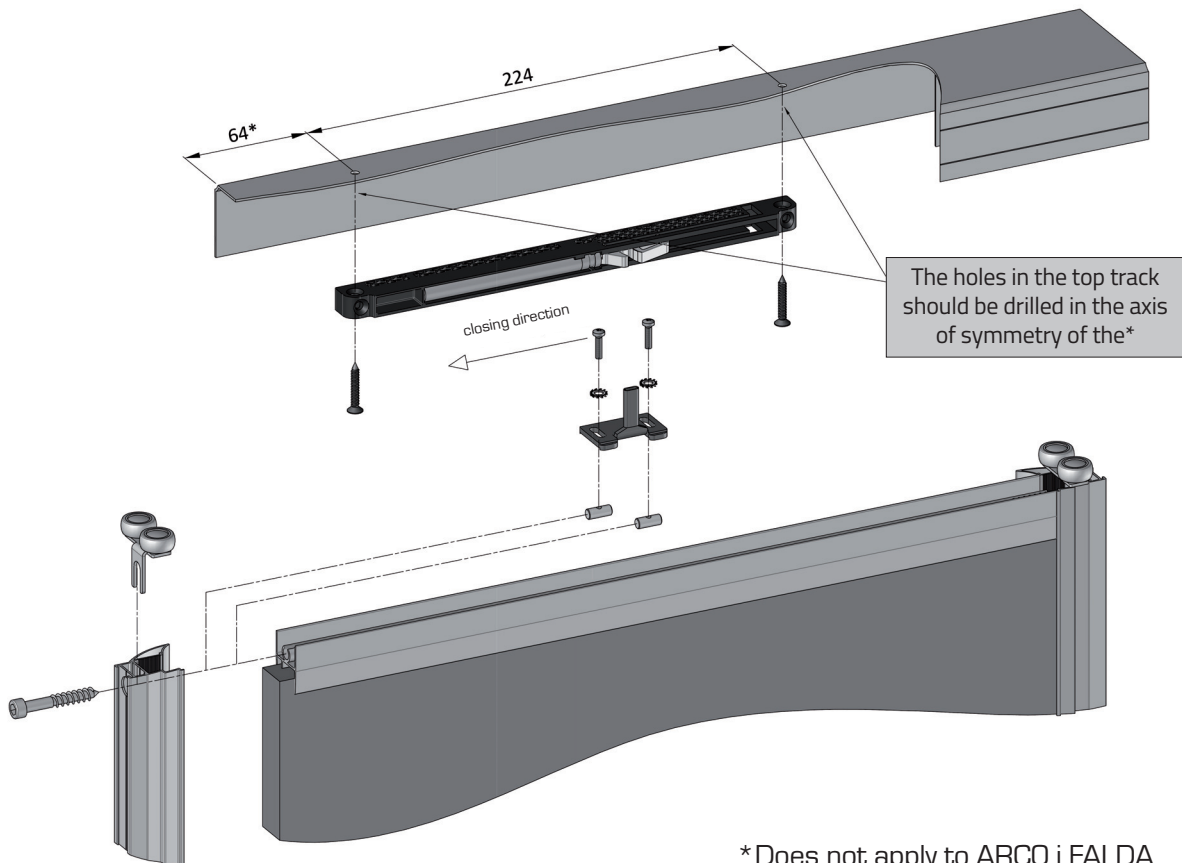
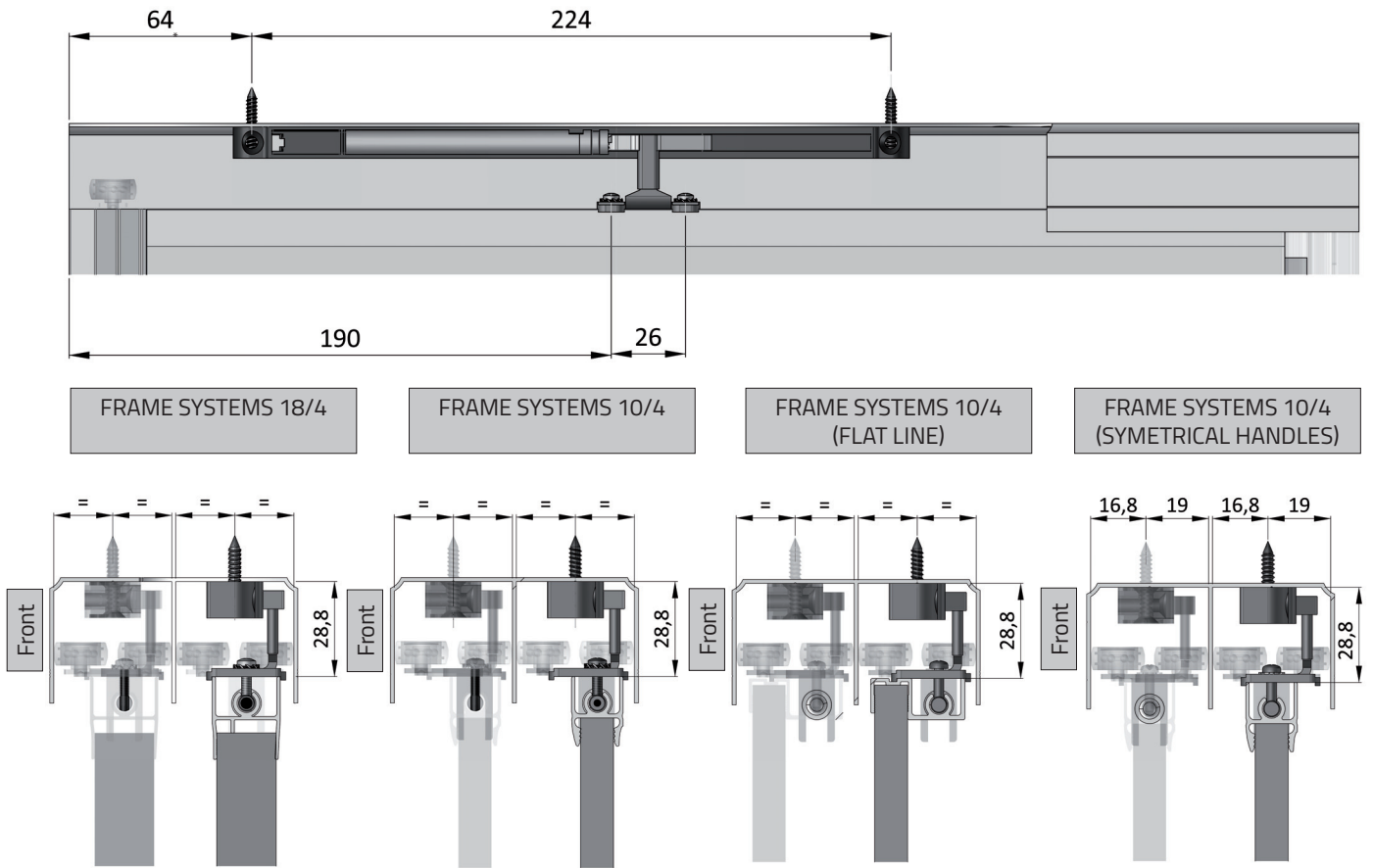

*Does not apply to ARCO i FALDA